



SMA Coaxial Interface

Grounded and Floating Shield Feedthroughs

UHV Double-Ended SMA Feedthrough, 110730, Conflat® compatible flange

UHV male SMA cable⁵ assembly, 110755, Kapton® insulated 50-ohm coaxial cable

Air-service male SMA cable⁵ assembly, 110765

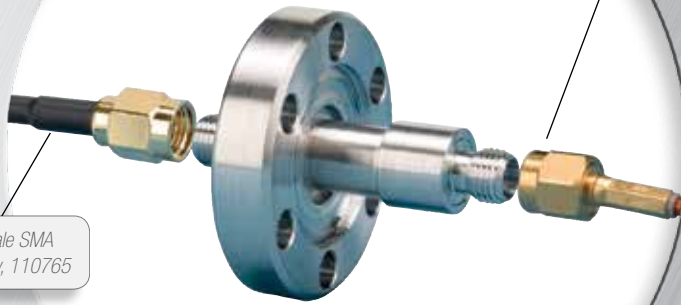

Features

- SMA Coaxial Interface
- Grounded and Floating Shield
- Single and Double Ended Configurations
- Kapton® insulated 50-Ohm cable
- High temperature rated to 250°C
- UHV compatible construction
- Conflat® and ISO KF compatible mounts
- Air service cables / connectors
- Custom solutions on request

Specifications

Electrical

Voltage ¹ , Maximum — Grounded Shield	700 VDC
Voltage ¹ , Maximum — Floating Shield	700 VDC
Current, Maximum @ 20°C	1 A
Impedance ² , Nominal	50 Ohms
Frequency ² , Nominal	6 GHz

Material

Shell	304 Stainless Steel
Pins	304 Stainless Steel
Insulation	Alumina Ceramic
Connector, Vacuum ³	
Accufast™	Stainless Steel, PEEK
SMA	Au plated brass, PEEK
Connector, Air	Teflon®
Cable Insulation	Kapton® Type-F Film

Vacuum Range

UHV, Ultrahigh vacuum	1x10 ⁻¹⁰ Torr
HV, High vacuum	1x10 ⁻⁸ Torr

Temperature Range⁴

Feedthrough, Single-Ended	250°C
Flange Mount, Conflat®	450°C
Flange Mount, ISO	150°C
Connector / Cable, Vacuum	250°C
Connector / Cable, Air	165°C
Thermal Gradient	25°C / Minute Maximum

Notes

1. Electrical ratings are maximum test values, with feedthrough's vacuum side at $\leq 1 \times 10^{-4}$ Torr. Feedthroughs are intended for instrumentation applications carrying low level signal voltage/current.
 2. Impedance and frequency ratings may vary with the type of interface cables and connectors used.
 3. PEEK is a polyether ether ketone thermoplastic.
 4. Overall assembly ratings must be adjusted to that of its lowest rated component. For cryogenic service, the lowest recommended temperature is -200°C
 5. Connectors and cables are not included with feedthrough and must be purchased separately.
- § Unless specified otherwise, dimensional units in all sections of this catalog are expressed in inches.

SMA Coaxial Interface

A 'Subminiature Type-A' coaxial connector, referred to as the SMA coaxial interface, is commonly used in conjunction with high-frequency, low noise 50-ohm instrumentation signal lines. SMA coaxial feedthroughs are constructed in both grounded and floating shield configurations. Floating shield types provide two concentric conductor paths: an outer metal conductor tube (shield) concentric with, and enclosing, a cylindrical center conductor pin. Both paths are electrically isolated from each other and a mounting flange. Grounded shield SMAs provide only one path that's electrically isolated from the flange, where grounded shield and flange are electrically common.

Vacuum side of single-ended grounded and floating SMA feedthroughs have a 0.094 inch (2.4-mm) diameter conductor pin that mates with grounded or floating AccuFast™ connectors. Vacuum compatible cable assemblies are fitted with Kapton® insulated 26 AWG, 50-ohm coaxial cable, with either Accufast™ connectors or gold-plated SMA connectors.

Grounded Shield — Single-Ended, No GHz Rating
Fig. 1

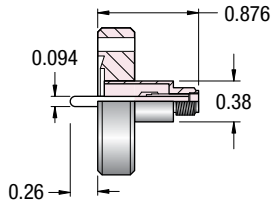

Double-Ended, 5-6 GHz Max
Fig. 2

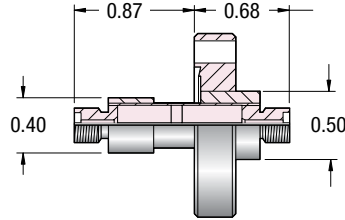

Floating Shield — Single-Ended, No GHz Rating
Fig. 3

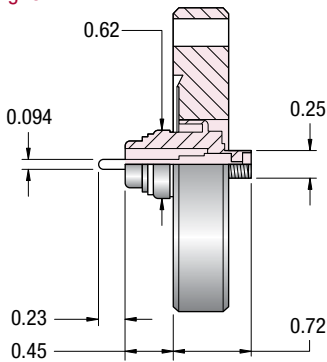

Double-Ended, 5-6 GHz Max
Fig. 4

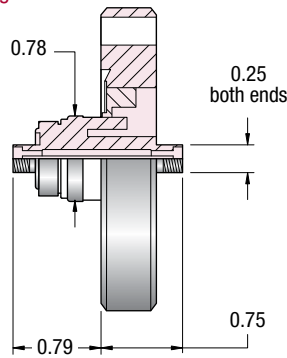

End Views showing feedthrough placements

No. Pins	SE Circle
1	—
2, 3	0.85
4, 5	1.00

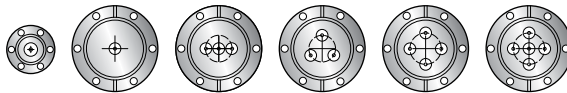

133 CF 275 CF

CF Flange¹ — 700VDC / 1 Amp / 250°C / UHV to 1x10⁻¹⁰ Torr

No. Pins	Fig.	End ² Type	CF Flange	OD	Model Number	Part Number	Unit Price \$
Grounded Shield							
1	1	SE	133 CF	1.33	SMA-GS-133	110731	216
1	1	SE	275 CF	2.73	SMA-GS-275	110736	242
2	1	SE	275 CF	2.73	SMA-GS2-275	110737	436
3	1	SE	275 CF	2.73	SMA-GS3-275	110738	646
4	1	SE	275 CF	2.73	SMA-GS4-275	110739	840
5	1	SE	275 CF	2.73	SMA-GS5-275	110742	1045
1	2	DE	133 CF	1.33	2SMA-GS-133	110730	546
1	2	DE	275 CF	2.73	2SMA-GS-275	110735	567
2 ³	2	DE	275 CF	2.73	2SMA-GS2-275	111015	1045
3 ³	2	DE	275 CF	2.73	2SMA-GS3-275	111016	1812
4 ³	2	DE	275 CF	2.73	2SMA-GS4-275	111017	2221
Floating Shield							
1	3	SE	275 CF	2.73	SMA-FS-275	110757	436
1	4	DE	275 CF	2.73	2SMA-FS-275	110758	856

1. Compatible with Coniflat® flanges and hardware 2. SE (single-ended) DE (double ended) 3. See website for detailed drawings welded in reverse from Fig. 2 above



110731 / Single-Ended SMA (Vacuum Side)



110730 / Double-Ended SMA (Vacuum Side)



110757 / Single-Ended SMA (Vacuum Side)



110758 / Double-Ended SMA (Vacuum Side)



Grounded Shield — Single-Ended, No GHz Rating
Fig. 1

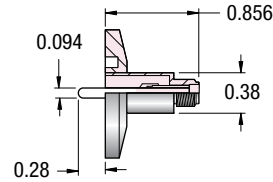

Double-Ended, 5-6 GHz Max
Fig. 2

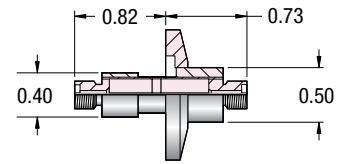

Floating Shield — Single-Ended, No GHz Rating
Fig. 3

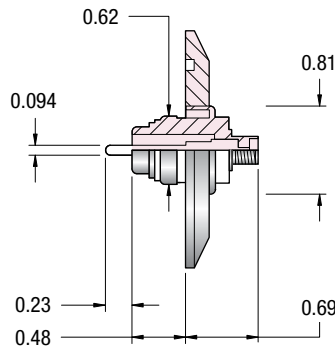

Double-Ended, 5-6 GHz Max
Fig. 4

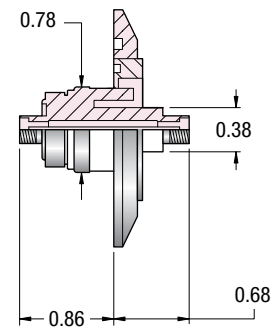

110746 / Single-Ended SMA
(Vacuum Side)



110740 / Double-Ended SMA
(Vacuum Side)



110759 / Single-Ended SMA
(Vacuum Side)



110762 / Double-Ended SMA
(Vacuum Side)

End Views showing
feedthrough placements

No. Pins	SE Circle
1	—
2 & 3	0.75
4 & 5	1.25



ISO KF Flange¹ — 700VDC / 1 Amp / 150°C / HV to 1x10⁻⁸ Torr

No. Pins	Fig.	End ² Type	ISO Flange	OD	Model Number	Part Number	Unit Price \$
Grounded Shield							
1	1	SE	NW16 KF	1.18	SMA-GS-K16	110741	216
1	1	SE	NW40 KF	2.16	SMA-GS-K40	110746	242
2	1	SE	NW40 KF	2.16	SMA-GS2-K40	110747	436
3	1	SE	NW40 KF	2.16	SMA-GS3-K40	110748	646
4	1	SE	NW50 KF	2.95	SMA-GS4-K50	110749	840
5	1	SE	NW50 KF	2.95	SMA-GS5-K50	110752	1045
1	2	DE ³	NW16 KF	1.18	2SMA-GS-K16	110740	546
1	2	DE ³	NW40 KF	2.16	2SMA-GS-K40	110745	567
2 ⁴	2	DE ³	NW50 KF	2.95	2SMA-GS2-K50	110754	1045
Floating Shield							
1	3	SE	NW40 KF	2.16	SMA-FS-K40	110759	436
1	4	DE ³	NW40 KF	2.16	2SMA-FS-K40	110762	856

1. Compatible with ISO 2861/1 specification flanges and hardware. 2. SE (single-ended) DE (double ended) 3. 5-6 GHz max
4. See website for detailed drawings not consistent with drawings above.

See page 80 for **Specifications**

Ultrahigh Vacuum Cable Assemblies

The cables in the assemblies listed below consist of Accu-Glass Products' TYP6, 26 AWG, coaxial cable (part number 100720, page 99). These components are UHV compatible to 1×10^{-10} Torr.

Connector to Cable UHV cable assemblies are fitted with stainless steel Accufast™ Female or SMA Male connectors at one end and a non-terminated, Kapton® insulated wire at the other. The connectors mate directly to the in-vacuum side of our SMA feedthrough flanges on pages 81 and 82.

Connector to User-Specified End UHV cable assemblies are fitted with stainless steel Accufast™ Female or SMA Male connectors at one end and a user-specified connector at the other: SMA Male, SMA Female or User-End Female.

Cables — 250°C / UHV to 1×10^{-10} Torr

Connector Type	Figure (Below)	Wire Length	Connector Name	Model Number	Part Number	Unit Price \$
Connector to Cable						
Grounded	1	19	Accufast™ 375	KAP-1CX-19AF375	110766	175
Grounded	1	39	Accufast™ 375	KAP-1CX-39AF375	110767	185
Floating	2	19	Accufast™ 620	KAP-1CX-19AF620	110768	175
Floating	2	39	Accufast™ 620	KAP-1CX-39AF620	110769	185
SMA	—	19	SMA Male	KAP-1CX-19SMA	110755	95
SMA	—	39	SMA Male	KAP-1CX-39SMA	110756	105

Connector to User-Specified End Options

1 contact	3	User-End Female	append to Part Number	.51	170
1 contact	—	SMA Male	append to Part Number	.52	90
1 contact	—	SMA Female	append to Part Number	.54	90

These are sold as additions to the above cable assemblies and are added at the factory only. Price is added to the unit price. For example, Part Number 110755.52 would have a price of \$185.

Grounded Shield

Fig. 1

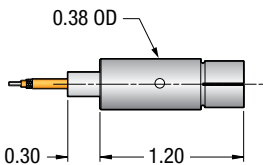

Floating Shield

Fig. 2

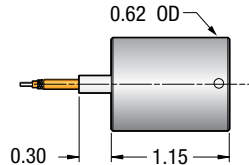

User-End

Fig. 3

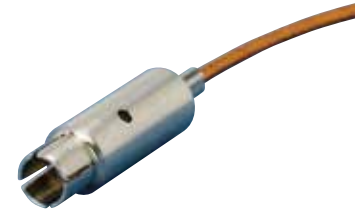
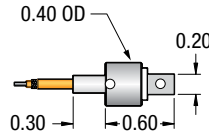

110766 / Grounded Shield Accufast™ 375 UHV Connector to Cable



110768 / Floating Shield Accufast™ 620 UHV Connector to Cable



.51, .52 and .54 / User End Female, SMA Male and SMA Female



110755.52 / SMA to SMA UHV Cable

Coaxial

See page 80 for **Specifications**

See page 94 for **Cable Specs**



111025 / Accufast™ 375 UHV Connector



111026 / Accufast™ 620 UHV Connector



111027 / SMA Male UHV Connector



111028 / SMA Female UHV Connector

Ultrahigh Vacuum Connectors

Components in this section are sold as the most basic components. Connectors do not include wire or cable.

Connectors are designed for use with our TYP6, 26 AWG, coaxial cable (part number 100720, page 99). Use of these connectors on other coaxial cable may require modification to the crimp sleeve of the connector. Please call before ordering if using with other coaxial cable.

Accufast™ 375 and 620 connectors mate directly to the vacuum side of corresponding single-ended feedthroughs on pages 81 and 82.

Connectors — 250°C / UHV to 1x10⁻¹⁰ Torr

Connector Type	Figure (Below)	Connector Name	Model Number	Part Number	Unit Price \$
Grounded	1	Accufast™ 375	AF375	111025	155
Floating	2	Accufast™ 620	AF620	111026	155
SMA	—	UHV SMA Male	SMA-UHV-P	111027	80
SMA	—	UHV SMA Female	SMA-UHV-S	111028	80
Generic	3	USER-END	USER-END	111022	145

Connector

Grounded Shield
Fig. 1

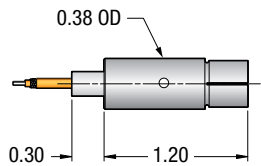

Floating Shield
Fig. 2

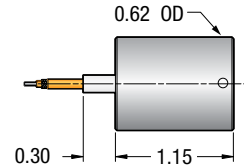

User-End
Fig. 3

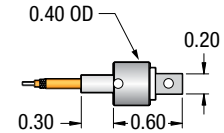

Assembly Tools and Components

Hex Crimping Tool	1 ea.	HCT-1	111029	95
UHV Solder	1 inch	UHV-SOLDER	110796	39
Solder Flux	1 ea.	S-FLUX	110797	45
Soldering Iron	1 ea.	S-IRON	110800	155

Air-service Cable Assemblies and Connectors

SMA Male to SMA Male air side cable assemblies are fitted with standard SMA connectors at both ends of an RG174/U coaxial cable. The connectors mate directly with the air side of our SMA feedthrough flanges on pages 81 and 82.



110765 / SMA to SMA Air-Service Cable

Cable Assembly, Connectors, and Cable — 80°C / Air Atmosphere

Number Contacts	Cable			Model Number	Part Number	Unit Price \$
	Length	Diameter	Termination Type			

Connector to Cable

1	48	0.25	SMA	AIR-SMA-482PC	110765	39
---	----	------	-----	---------------	---------------	----

Connector to User-Specified End Options

SMA Male	—	—	SMA	AIR-SMA-C	110772	18
----------	---	---	-----	-----------	---------------	----



110772 / Air-Service SMA Male Connector