



Fused Silica Viewports

UV or deep UV fused silica are vacuum brazed to stainless sleeves, producing UHV hermetic quartz-to-metal seals.

UV and/or Deep UV Synthetic Fused Silica Substrate

Ultrahigh Vacuum Compatible Materials

Vacuum Brazed Quartz-to-metal Seal

Fused Silica Viewports

Accu-Glass' Fused silica viewports are rated for both high and ultrahigh vacuum applications. Viewports are offered in two (2) fused silica grades... our UV (ultraviolet) material is suitable for most optical applications and certified to meet or exceed 80% external transmittance at 185nm. The DUV (deep ultraviolet) grade is equivalent to Suprasil-1® and with the exception of inclusion specification, is virtually identical to the UV material. Fused silica viewports outperform glass viewports in their transparency to ultraviolet radiation and offer a high resistance to discoloration. Since poor surface finish can contribute as much as 10% to overall transmission losses, our UV and DUV viewports are supplied with flat faces that have been polished to a 40-20 and 20-10 scratch-DIG specification respectively. DUV viewports are recommended for service below 200nm.

Transmission Curve

Fused Silica (Quartz) Substrate (0.39 inch Thick)

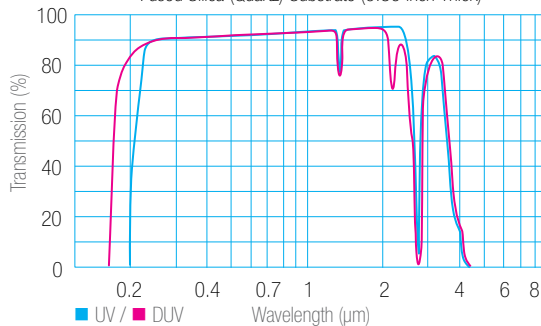

Features

- Fused Silica (Synthetic Quartz)
- Ultraviolet and deep ultraviolet grades
- Optically polished substrate faces
- UHV compatible construction
- High Temperature rated to 200°C
- Stainless steel construction
- Conflat® and ISO NW compatible mounts
- Custom Solutions on Request

Specifications

Material

Flange	304 Stainless Steel
Glass Substrate	Fused Silica
Seal	Vacuum Brazed

Vacuum Range ¹

UHV, Ultrahigh vacuum	1x10 ⁻¹⁰ Torr
HV, High vacuum	1x10 ⁻⁸ Torr

Temperature Range ²

Seal (braze joint)	200°C
Flange Mount, Conflat®	450°C
Flange Mount, ISO	150°C
Thermal Gradient	20°C / Minute Maximum

Transmission Range ³

200-2000nm (UV Grade)	≥80%
40-20 scratch-dig finish on both faces	
185-2000nm (Deep UV Grade)	≥80%
20-10 scratch-dig finish on both faces	

Notes

1. Leak tested to 5x10⁻¹⁰ Standard cc/sec of He.
2. Overall assembly ratings must be adjusted to that of lowest rated component. Fused silica-to-metal seal is a low temperature lead-silver braze alloy that melts at 305°C. Temperature monitoring sensors should always be placed between heat source and braze joint... i.e. when heat source originates inboard of seal/braze joint (through center of window), sensor must be placed on window substrate, outboard of heat source, but inboard of seal/braze joint. Conversely, if heat source originates outboard of seal/braze joint, sensor must be placed on stainless steel sleeve outboard of seal/braze joint.
3. Transmission curves are provided for reference only. Transmission for individual viewports may vary based on thicknesses, surface finish and/or other conditions.
- § Unless specified otherwise, dimensional units in all sections of this catalog are expressed in inches.

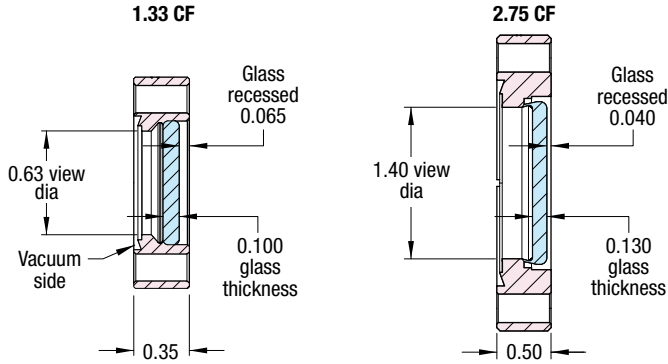

112658 / UHV Fused Silica Viewport mounted on 1.33 CF Flange

CF Flange¹ — Fused Silica Viewports / 200°C / UHV to 1x10⁻¹⁰ Torr

View Diameter	Flange Type	Flange OD	Window Thickness	Spectral Range nm	Model Number	Part Number	Unit Price \$
---------------	-------------	-----------	------------------	-------------------	--------------	-------------	---------------

UV — Ultraviolet Grade Substrate

0.63	133 CF	1.33	0.085	200-2000	VPFS-UV0.6-133	112658	231
1.40	275 CF	2.73	0.130	200-2000	VPFS-UV1.4-275	112659	252

DUV — Deep Ultraviolet Grade Substrate

0.63	133 CF	1.33	0.085	185-2000	VPFS-DUV0.6-133	112660	389
1.40	275 CF	2.73	0.130	185-2000	VPFS-DUV1.4-275	112661	441

1. Compatible with Conflat® flanges and hardware



112659 / UHV Fused Silica Viewport mounted on 2.75 CF Flange

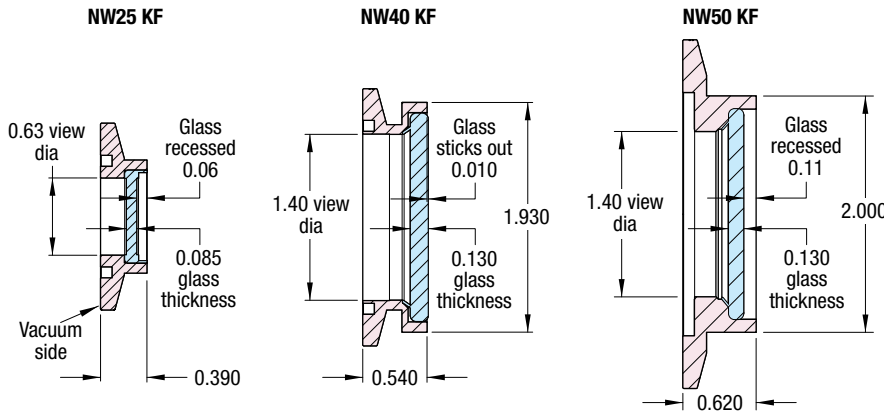

112662 / HV Fused Silica Viewport mounted on NW16 KF ISO Flange

ISO KF Flange¹ — Fused Silica Viewports / 150°C / HV to 1x10⁻⁸ Torr

View Diameter	Flange Type	Flange OD	Window Thickness	Spectral Range nm	Model Number	Part Number	Unit Price \$
---------------	-------------	-----------	------------------	-------------------	--------------	-------------	---------------

UV — Ultraviolet Grade Substrate

0.63	NW25 KF	1.57	0.085	200-2000	VPFS-UV0.6-K25	112662	237
1.40	NW40 KF	2.16	0.130	200-2000	VPFS-UV1.4-K40	112663	263
1.40	NW50 KF	2.95	0.130	200-2000	VPFS-UV1.4-K50	112664	315

1. Compatible with ISO 2861/1 specification flanges and hardware



112664 / HV Fused Silica Viewport mounted on NW50 KF ISO Flange