



Access Doors

2.56 and 3.81 Inch Through-Bores

195° Degree (120° Optional)
door swing angle, with blank or viewport
fitted door

Adjustable, dual-axis hinge
mechanism for improved
gasket seating

Quick and simple over-center
latching mechanism with cotter pin
security option

Access Doors

Accu-Glass Products is pleased to introduce an improved line of vacuum access doors on 4.5 and 6.0 inch Conflat® compatible flange mount sizes. They're available with blank or zero-length glass viewport doors. Viewport fitted doors are constructed with Corning® 7056 borosilicate glass and Kovar® (nickel-iron) low-expansion metal sleeves, which are TIG welded to the door's frame. The 4.5 and 6 inch CF access doors have 2.56 and 3.81 clearance bores respectively. However, please note that maximum bore clearance may be limited by existing system's mating hardware and geometry.

Our access doors employ a unique, adjustable dual-axis hinge mechanism that exerts even pressure on the door's elastomer seal, for fast reliable closures and pump-down cycles. Although standard doors have a 195° swing-angle, an optional door-stop kit will reduce swing-angle to 120° maximum... a helpful feature in tight laboratory settings. All doors are supplied with a Viton® elastomer gasket that is suitable for high vacuum service. Access door closure is accomplished with a simple over-center latching mechanism that's quick and easy to use, which can be fitted with a security cotter pin (included) to prevent accidental unlatching when system is not under vacuum. AG access doors can be mounted to both clearance or threaded CF mating system flanges. Bolt kits are available for either mounting arrangement and include all necessary fastening hardware... bolts, nuts and washers.

Larger or smaller custom access door sizes, as well as blind threaded mounting hole doors (for reverse bolting arrangements) are available on request.

Features

- 195° Swing, Blank / Viewport fitted doors
120° swing is optional
- 2.56 and 3.88 Inch door apertures
- 7056 Borosilicate glass¹
- Adjustable, dual-axis hinge mechanism
- Over-center latch mechanism with lock
- Elastomer gasket door seal
- High vacuum compatible to 10⁻⁸ Torr
- Conflat® compatible mounts with counter bored clearance bolt interface²
- Custom Solutions on Request

Specifications

Material

Flange and Door	304 Stainless Steel
Viewport	
Substrate	7056 Borosilicate Glass
Metal Transition	Kovar® (NiFe Alloy)
Seal, Elastomer Door	Viton®

Vacuum Range³

HV, High vacuum	1x10 ⁻⁸ Torr
-----------------	-------------------------

Temperature Range⁴

Blank Door (without elastomer seal)	150°C
Glass Door (without elastomer seal)	150°C
Seal, Elastomer Door	150°C
Thermal gradient, °C/minute maximum (glass)	20°C

Notes

1. Viewing aperture and/or glass specifications are only applicable to viewport-fitted access doors.
 2. See bolt hole orientation schematic on facing page
 3. Leak tested to 5x10⁻¹⁰ Standard cc/sec of He.
 4. Overall assembly ratings must be adjusted to that of its lowest rated component.
- § Unless specified otherwise, dimensional units in all sections of this catalog are expressed in inches.

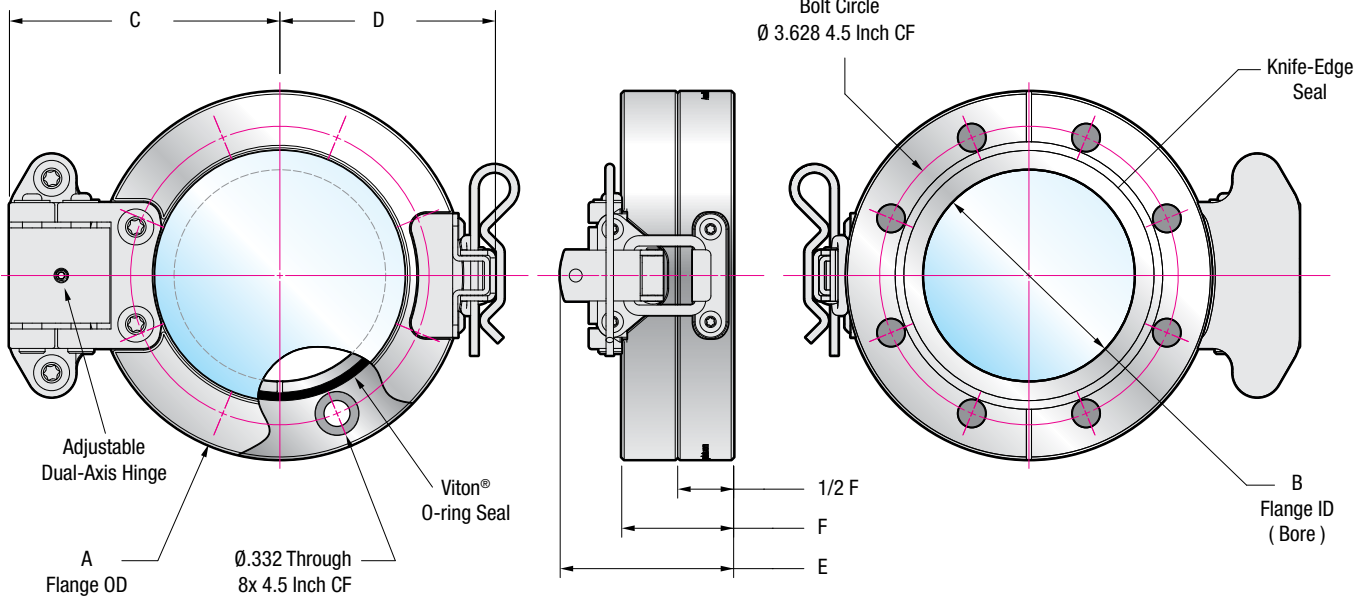

CF Flange — Access Doors with .332 Clearance Holes / 150°C / HV to 1x10⁻⁸ Torr

Flange Size	Flange OD A	Flange ID B	C	D	E	F	Bolt Holes	Model Number	Part Number	Unit Price \$
-------------	-------------	-------------	---	---	---	---	------------	--------------	-------------	---------------

Viewport Fitted — 7056 Borosilicate Glass

450 CF	4.47	2.56	3.30	2.63	2.11	1.36	8	AD-VP-450C	112945	855
--------	------	------	------	------	------	------	---	------------	---------------	-----

Blank — 304 Stainless Steel

450 CF	4.47	2.56	3.30	2.63	2.11	1.36	8	AD-450C	112921	745
--------	------	------	------	------	------	------	---	---------	---------------	-----

Larger or smaller custom size doors available on request / Compatible with Coniflat® flanges



112945 / Viewport 4.5 CF Access Door
7056 Borosilicate Glass

Hardware — Fastener Kits / Door-Stop / Replacement Gaskets

Flange Size	Bolt Thread Size	Bolt Length	Qty Pckg	Model Number	Part Number	Unit Price \$
-------------	------------------	-------------	----------	--------------	-------------	---------------

Threaded Hole Kit — Fasten to threaded-hole system flange / Includes bolts only

450 CF	5/16-24	1.00	8	ADH-TH450	112963	18
--------	---------	------	---	-----------	---------------	----

Clearance Hole Kit — Fasten to clearance-hole system flange / Includes bolts, nuts and washers

450 CF	5/16-24	1.50	8	ADH-CH450	112965	20
--------	---------	------	---	-----------	---------------	----

120° Door-Stop Kit^{1,2} — Fits both 4.5 and 6 inch door sizes / Includes two screws

Reduces standard door swing-angle from 195° to 120°				ADH-120-DS	112980	10
---	--	--	--	------------	---------------	----

Door Gasket — Spare / Replacement Viton® elastomer O-ring seals

450 CF	0.103 x 2.80 OD	1	ADH-DGV-450	112981	4
--------	-----------------	---	-------------	---------------	---

1. Keeps door from swinging into other hardware in tight laboratory settings 2. User installed (or factory installed by request)



112921 / Blank 4.5 CF Access Door
Solid Stainless Steel